

BRISTAN

Sail Tap Range

Installation Instructions & User Guide



Please keep these instructions for future reference and request of replacement parts

Contents

Thank you for choosing Bristan, the UK's leading taps and showers expert. We have designed this product with your enjoyment in mind. To ensure that it works to its full potential, it needs to be fitted correctly. These fitting instructions have been created to give you all of the information you need and, if you need any further help, please do not hesitate to give us a call on 0844 701 6273.

Important Safety Information	03
General Specifications	03
Dimensions	04-05
Installation Requirements	06
Installation	07-12
Basin & Bath Taps	07
Basin Mixer	08
Bath Filler	09
Bath Shower Mixer	10-11
Maintenance	12-14
Map of Hard Water Regions in the UK	15
Troubleshooting	16
Guarantee	17

Important Safety Information

- Please read these instructions thoroughly and retain for future use.
- All products manufactured and supplied by Bristan are safe provided they are installed correctly, used correctly and receive regular maintenance in accordance with these instructions.
- **If you are in any doubt about your ability to install this product safely you must employ the services of an experienced qualified plumber.**
- Remove all packaging and check the components for damage before starting installation.
-  Before starting any installation please consider the following: Prior to drilling into walls, check that there are no hidden electrical wires, cables or water supply pipes. This can be checked with the aid of an electronic detector.
- If power tools are used do not forget to:
 - Wear eye protection
 - Unplug equipment after use
- This product **must** not be modified in any way as this will invalidate the guarantee.
- These fittings need to be installed in accordance with and meet the requirements of the Water Supply (Water Fittings) Regulations 1999 and Scottish Byelaws 2004.

General Specifications

Operating pressure range (bar)	Min	Max
Basin Taps	0.2	5.0
Bath Taps	0.2	5.0
Basin Mixer	0.2	5.0
Bath Shower Mixer	0.2	5.0
Bath Filler	0.2	5.0

Maximum static pressure – 10.0 bar

NOTE:- Nominally equal (balanced) inlet supply pressures are recommended for optimum Performance of mixer taps.

Designed to comply with BS EN 200 for single taps / combination taps for water systems of type 1 and 2 general technical specifications; and to be used within systems designed to BS 6700.

BS 6700 recommends the temperature of stored water should never exceed 65°C. A stored water temperature of 60°C is considered sufficient to meet all nominal requirements and will minimise the build up of lime scale in hard water areas.

BRISTAN

Dimensions

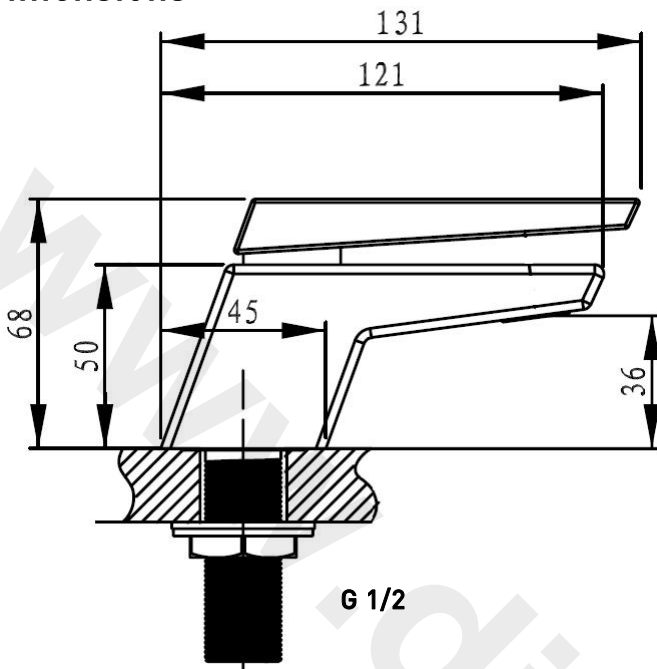

1/2" Basin Taps

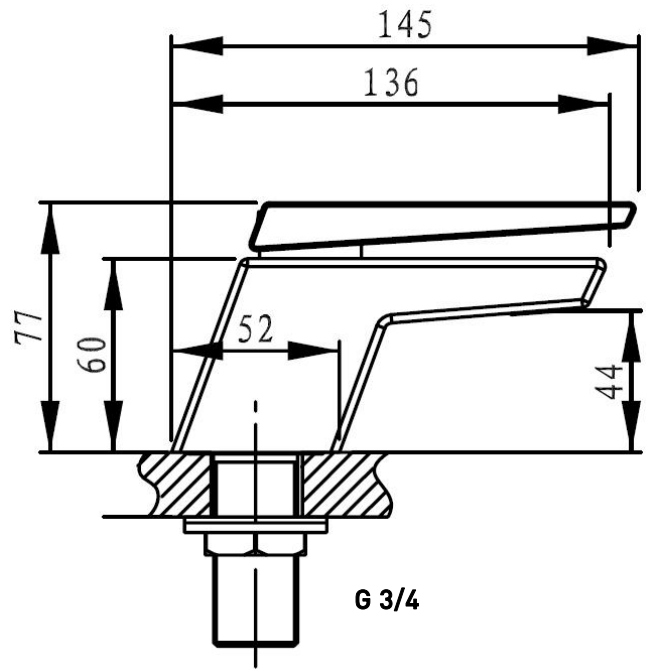

3/4" Bath Taps

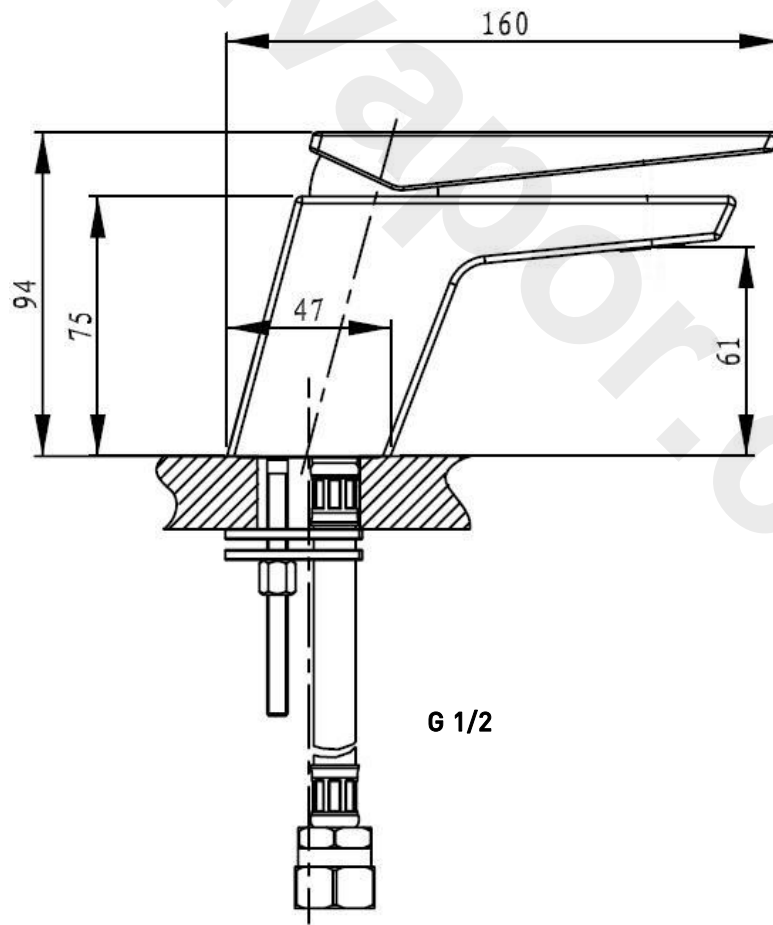

Basin Mixer

Dimensions Cont.

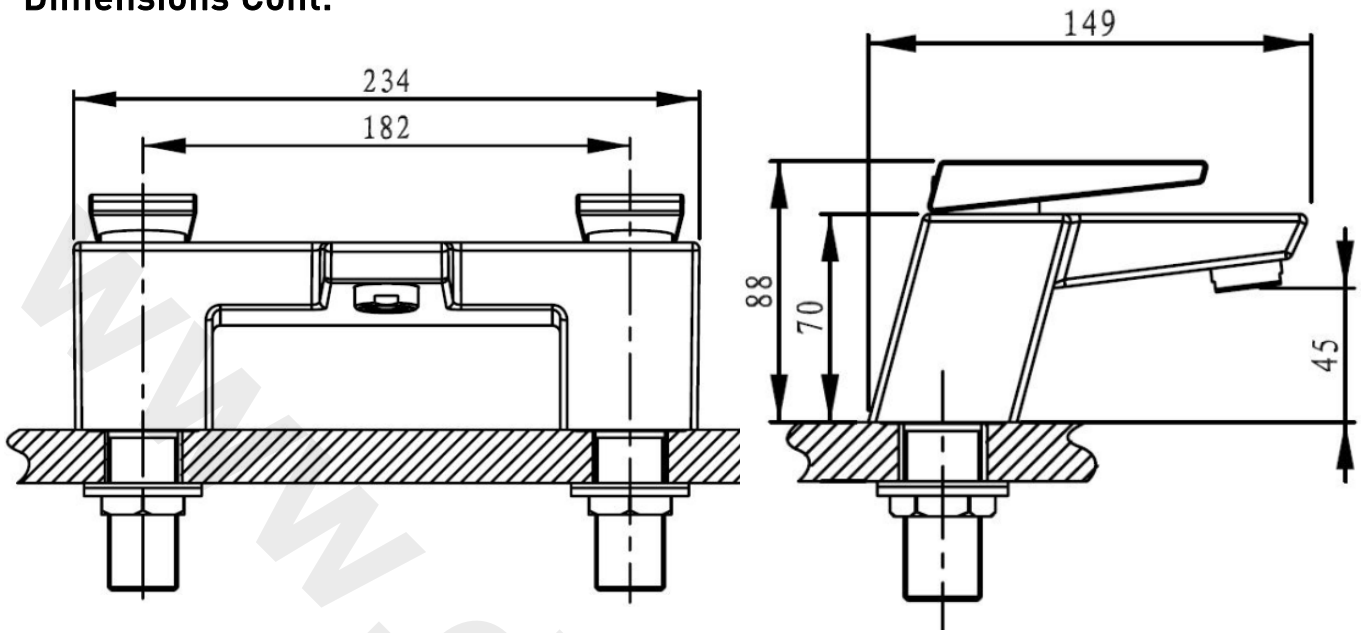

Bath Filler

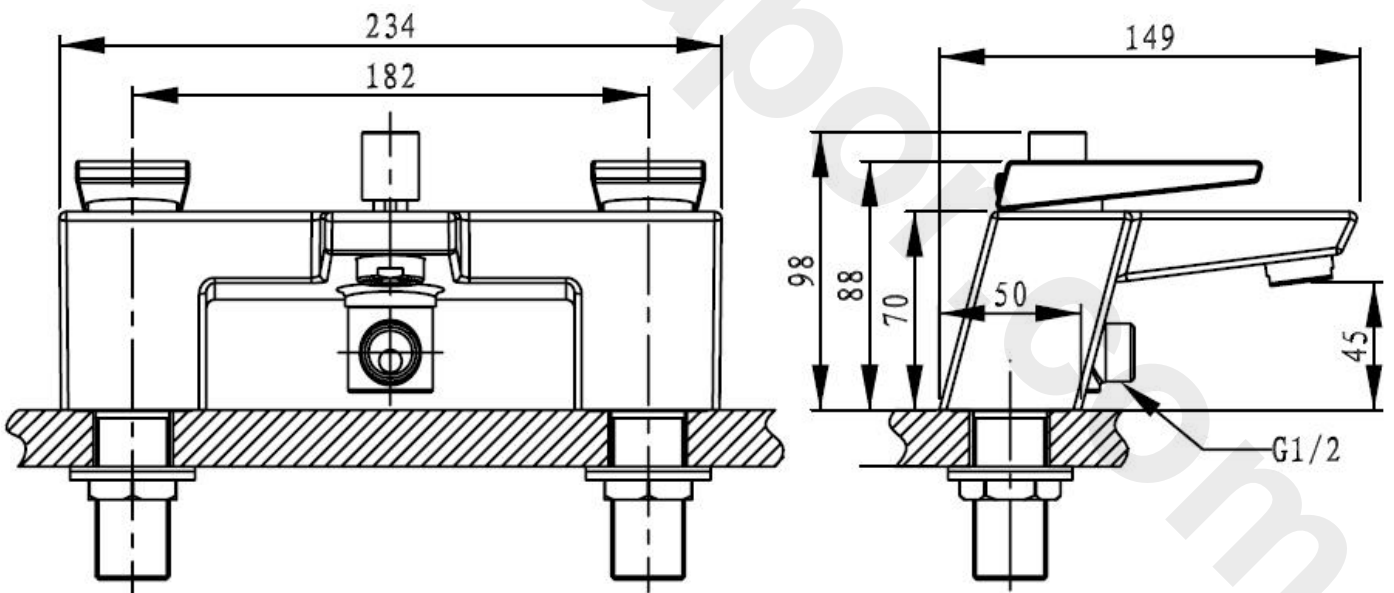

Bath Shower Mixer

Installation Requirements

IMPORTANT - PLEASE READ

This/these fitting/fittings needs/need to be installed in accordance with the following Installation Requirements and Notes (IRN) to ensure they meet the requirements of the Water Supply (Water Fittings) Regulations 1999 and the Scottish Byelaws 2004.

IRN R001: SAI ½ C, SAI ¾ C, SAI BAS C, SAI BF C, SAI BSM C

See text of entry for Installation Requirements or Notes.

IRN R005: SAI BF C, SAI BSM C

This tap or combination tap assembly has a Type AUK2 air gap and is therefore only suitable for installation in domestic premises or in other premises to protect against a backflow risk up to a Fluid Category 3, unless additional backflow protection for the higher risk is included in the installation.

IRN R006: SAI ½ C, SAI ¾ C, SAI BAS C

This tap or combination tap is installed so that its base is no lower than the spillover level of the receiving vessel (for example, a sink or washbasin), a Type AUK3 air gap is achieved which permits installation of the tap in any premises where backflow protection up to Fluid Category 5 is required at the tap.

IRN R010: SAI BAS C, SAI BF C
Schedule 2-15 (1)

Water supplies shall be a reasonably balanced pressures from a common source (e.g. hot and cold supplies both from the same storage or both from a supply pipe). Where the fitting is supplied from unbalanced supplies (e.g. hot and cold supplies from separate sources) a **'Listed' single check valve** or some other no less effective backflow prevention device shall be fitted immediately upstream of both hot and cold water inlets.

IRN R030 – SAI BSM C - Schedule 2-15 (1)

Multiple inlet fittings installed in domestic premises or in other premises to protect against a backflow risk up to a Fluid Category 3, incorporating a self cancelling diverter acceptable as a backflow prevention device (HC) and having an AUK2 or AUK3 air gap, shall be installed in accordance with IRN R010.

Multiple inlet fittings installed in premises other than domestic to protect against a backflow risk up to a Fluid Category 5, incorporating a self cancelling diverter acceptable as a backflow prevention device (HC only) and having an AUK2 or AUK3 air gap, shall be installed in accordance with IRN R010. Alternatively the fitting shall be supplied in accordance with IRN R040 unless the shower head is constrained above the spill-over lever of the bath, wash basin or shower tray.

Installation

½" Basin & ¾" Bath Taps

1. Identify all components are present prior to starting installation.
2. Position the 'O' ring (10) in the groove on the underside of the tap body and install the taps to the basin/bath.
3. Using the washer (11) and metal backnuts (12), secure the taps to the basin by tightening the backnuts onto the pre-fitted threaded tails. A suitable spanner may be required to fully tighten the backnuts (12).
4. Connect the hot and cold water supplies to the taps.
5. Turn on the water supplies and open both taps letting the water flow for a few minutes to check all joints and connections for any leaks.

- | | | |
|-----|----------------------------------|----|
| 1. | Grub Screw Cap
(SAI ¾ C only) | x2 |
| 2. | Grub Screw | x2 |
| 3. | Handle | x2 |
| 4. | Shroud | x2 |
| 5. | O-Ring | x2 |
| 6. | Spline Adapter | x2 |
| 7. | Ceramic Disc Valve | x2 |
| 8. | Tap Body | x2 |
| 9. | Anti-Splash | x2 |
| 10. | 'O' Ring | x2 |
| 11. | Rubber Washer | x2 |
| 12. | Metal Backnut | x2 |

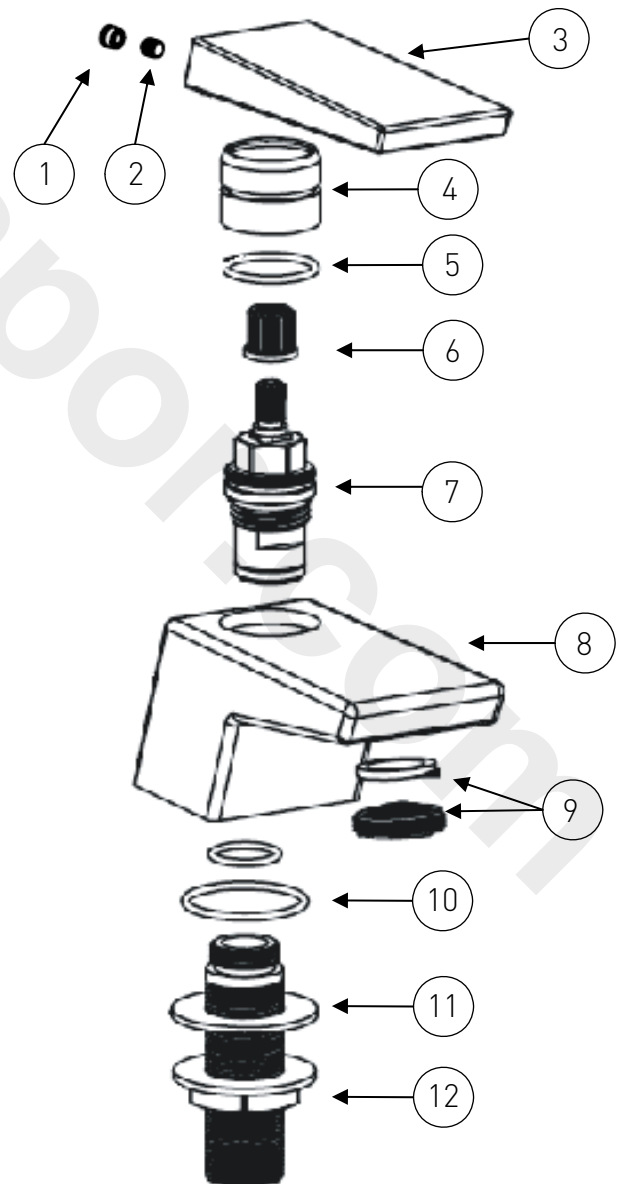

Installation cont.

Basin Mixer

1. Identify all components are present prior to starting installation using the diagram overleaf.
2. Fit the mixer body (6) to the basin ensuring the o-ring (8) is fitted between the basin and the mixer body (6).
3. From the fixing kit (9), Screw the two fixing rods into the bottom of the mixer body (6). Push the 'C' shaped rubber and metal washers onto the threaded rods and tighten by screwing the fixing nuts accordingly..
4. Screw in (by hand only) the flexible connecting pipes (10) to the mixer, by hand only; **(DO NOT OVERTIGHTEN)** and connect the hot and cold water supplies.
5. Fit the clicker waste (11) to the basin ensuring a rubber washer is fitted between the basin and the waste. Use a pure silicon sealant where necessary. Place the other rubber washer under the basin and secure in place by tightening the backnut. In order to fill the basin, push down the middle of the waste. To release the water, press the middle again.
6. Lift the handle up and turn in both directions, letting the water flow for a few minutes to check all joints and connections for any leaks.

1.	Handle	x1
2.	Grub Screw	x1
3.	Shroud	x1
4.	Cartridge Retaining Nut	x1
5.	Cartridge	x1
6.	Mixer Body	x1
7.	Anti-Splash	x1
8.	'O'-Ring	x1
9.	Fixing Kit	x1
10.	Flexible Tails	x2
11.	Clicker Waste (Not Shown)	x1

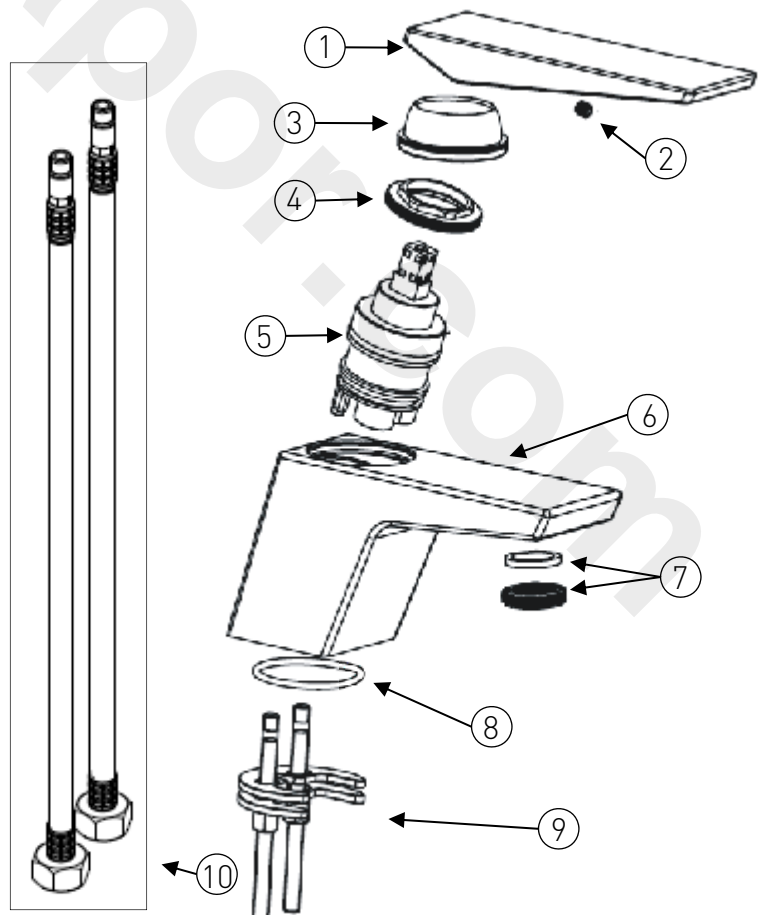

Installation cont.

Bath Filler

1. Identify all components are present prior to starting installation.
2. Position 'O' rings (10) in the groove on the underside of the mixer body and install the mixer body (8) to the bath.
3. Using the washers (11) and the backnuts (12) secure the mixer body (8) to the bath by tightening the backnuts (11) onto the pre-fitted threaded tails. A suitable spanner maybe needed to fully tighten the backnuts (12).
4. Connect the hot and cold water supplies using 3/4" tap connectors (not supplied).
5. Turn the handles in both directions, letting the water flow for a few minutes to check all joints and connections for leaks.

- | | | |
|-----|--------------------|----|
| 1. | Grub Screw Cap | x2 |
| 2. | Grub Screw | x2 |
| 3. | Handle | x2 |
| 4. | Shroud | x2 |
| 5. | O-Ring | x2 |
| 6. | Spline Adapter | x2 |
| 7. | Ceramic Disc Valve | x2 |
| 8. | Mixer Body | x1 |
| 9. | Anti-Splash | x1 |
| 10. | 'O' Ring | x2 |
| 11. | Rubber Washer | x2 |
| 12. | Metal Backnut | x2 |

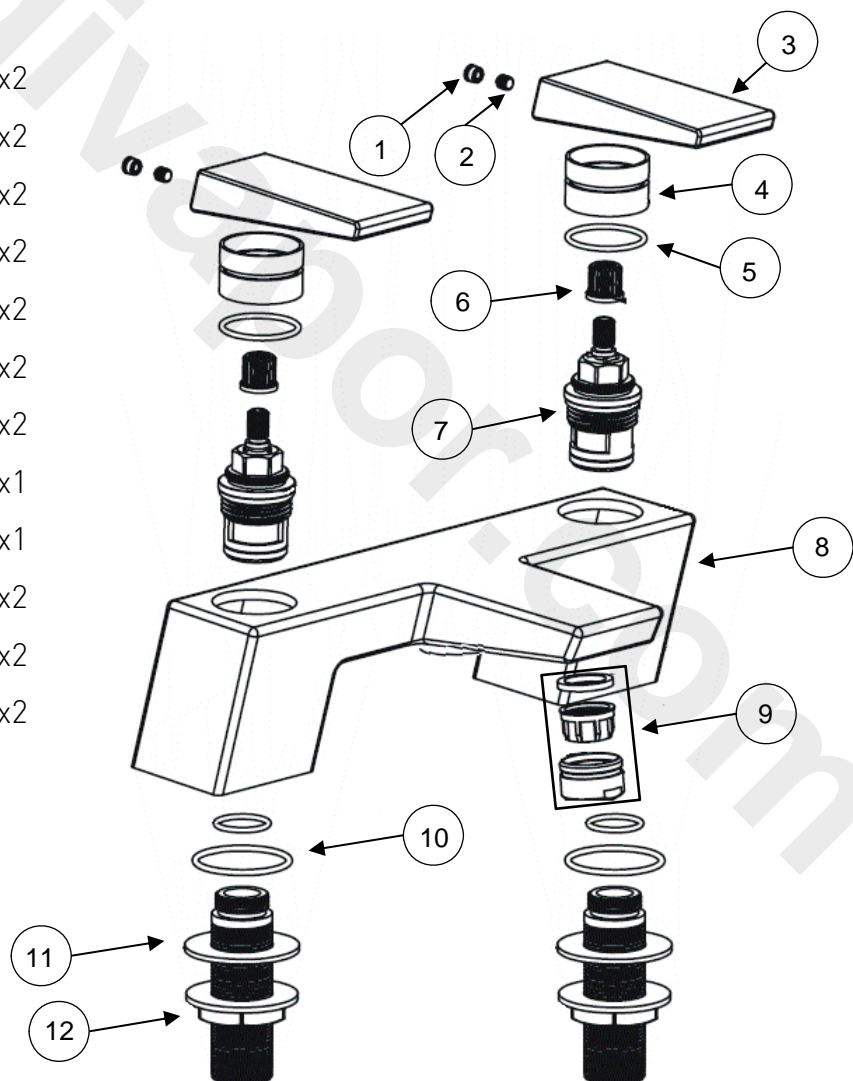

Installation cont.

Bath Shower Mixer

1. Identify all components are present prior to starting installation using the diagram overleaf.
2. Position 'O' rings (10) in the groove on the underside of the mixer body and install the mixer body (9) to the bath.
3. Using the washers (11) and the backnuts (12) secure the mixer body (9) to the bath by tightening the backnuts (12) onto the pre-fitted threaded tails . A suitable spanner may be required to fully tighten the backnuts (12).
4. Connect the hot and cold water supplies using ¾" tap connectors (not supplied).
5. Fit the shower hose (14) to the hose outlet using the small washer, and the handset (16) to the hose using the small washer.
6. Fit the wall bracket (Not Shown) to the wall using the fixings supplied, ensuring the handset (16) and hose (14) reaches it.
7. Turn the handles in both directions, letting the water flow for a few minutes to check all joints and connections for leaks.
8. To switch from bath to shower mode, pull the diverter knob (7) up, to revert back to bath filling mode push the diverter knob back down.

1.	Grub Screw Cap	x2	9.	Mixer Body	x1
2.	Grub Screw	x2	10.	'O' Ring	x2
3.	Handle	x2	11.	Rubber Washer	x2
4.	Shroud	x2	12.	Metal Backnut	x2
5.	O-Ring	x2	13.	Diverter Mechanism	x1
6.	Spline Adapter	x2	14.	Hose	x1
7.	Diverter Knob	x1	15.	Anti-Splash	x1
8.	Ceramic Disc Valve	x2	16.	Handset	x1

Installation cont.

Bath Shower Mixer

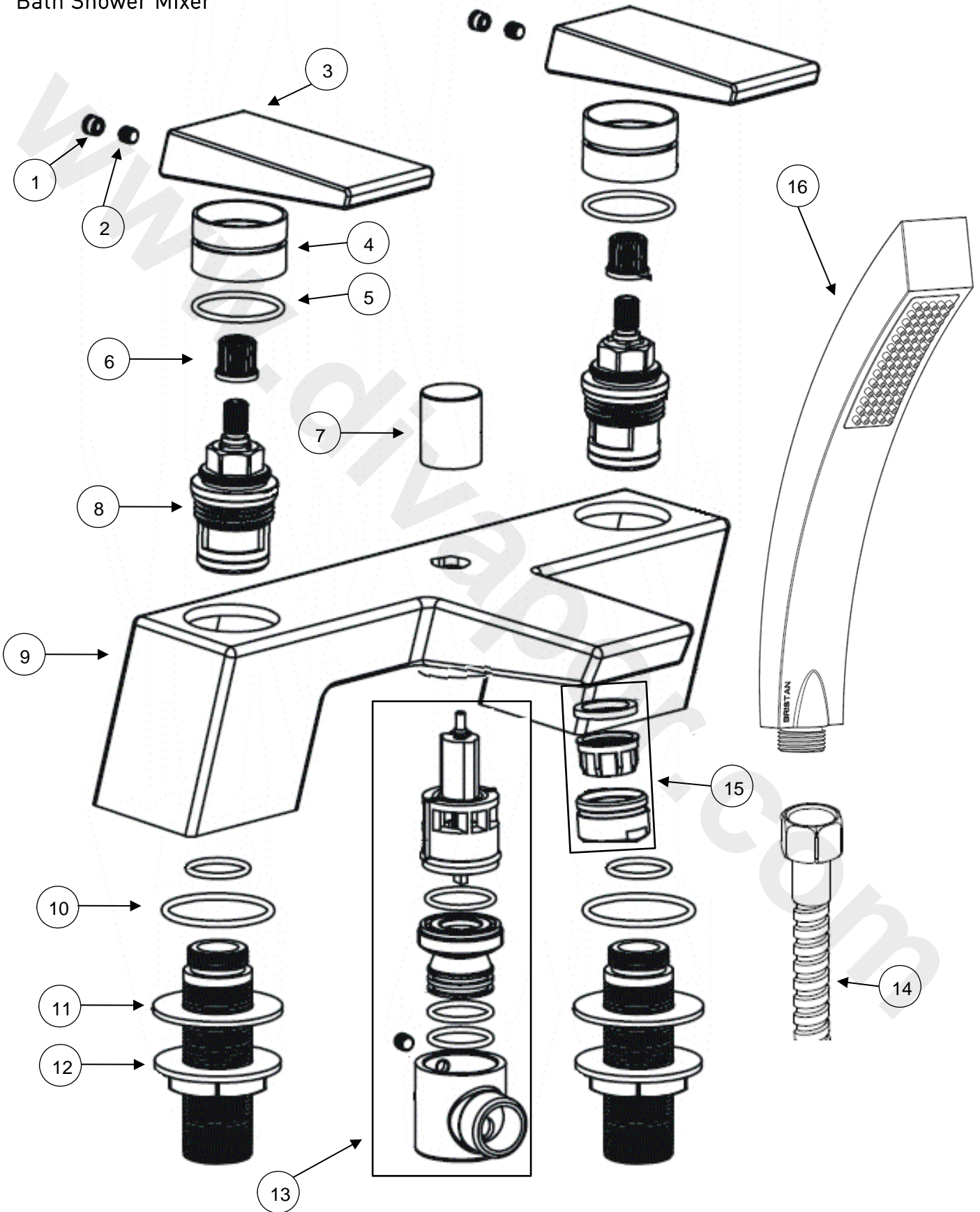

Maintenance

General Cleaning

Your fitting has a high quality finish and should be treated with care to preserve the visible surfaces. All finishes will wear if not cleaned correctly. The only safe way to clean your product is to wipe with a soft damp cloth. Stains can be removed using washing up liquid. All bathroom cleaning products (powders and liquids) will damage the surface of your fitting, even the non-scratch cleaners.

Note: Never use abrasive detergents or disinfectants or those containing alcohol, hydrochloric acid or phosphoric acid.



Bristan recommend E-cloth for cleaning all of our bathroom & kitchen products. Using just water, E-cloth gives a smear free, deep clean by breaking up and holding dirt, which normal cloths leave behind. Order through your Bristan stockist (order code: E CLOTH).

Cleaning the Showerhead – SAI BSM C

Your Bristan showerhead has rub-clean nozzles for easy cleaning. Simply rub your fingers across the rubber spray jets regularly and before you turn the shower on to remove any scale or debris.

The hardness of the water in your area will determine how often you should clean your showerhead. Build up of scale in particularly hard water areas combined with constant use means you may need to clean your showerhead once a week. To ensure continued performance the showerhead needs to be regularly descaled.

See map of Hard Water Regions in the UK on page 16 to see the water type in your area.

Tip: If the showerhead is heavily scaled or has not be maintained for a long period of time a solution of hot water and white vinegar may be needed to clear the scale.

Mix a 50/50 solution and rub the nozzles thoroughly with the solution making sure the solution gets into all of the nozzles.

Wash off the solution with clean water.

Maintenance cont.

Cleaning the Valves – Basin Taps, Bath Tap, Bath Filler and Bath Shower Mixer

We advise that your fitting is regularly serviced in hard water areas to maintain optimum performance (see map of Hard Water Regions in the UK on page 15).

If your fitting begins to leak the following should be carried out;

Isolate both hot and cold water supplies to the tap by either:

- Turning the water supply off at the mains stopcock or
- Turning off the isolation valves to the tap.

1. If needed, remove the cap at the rear of the handle to reveal the concealed grub screw.
2. Unscrew the grub screw and pull the handle upwards from the shroud.
3. Unscrew the shroud and using a suitable spanner remove the valve from the tap body.
4. Clean the valve and the seating inside the tap body.
5. If necessary replace the valve.

Please visit www.bristan.com/sparesfinder in order to find spare parts for this product.

6. Replace the valve into the tap body and tighten fully using a suitable spanner.
7. Replace handle assembly.
8. Turn on water supply and check for leaks.
9. Contact our helpline should if problem persists.

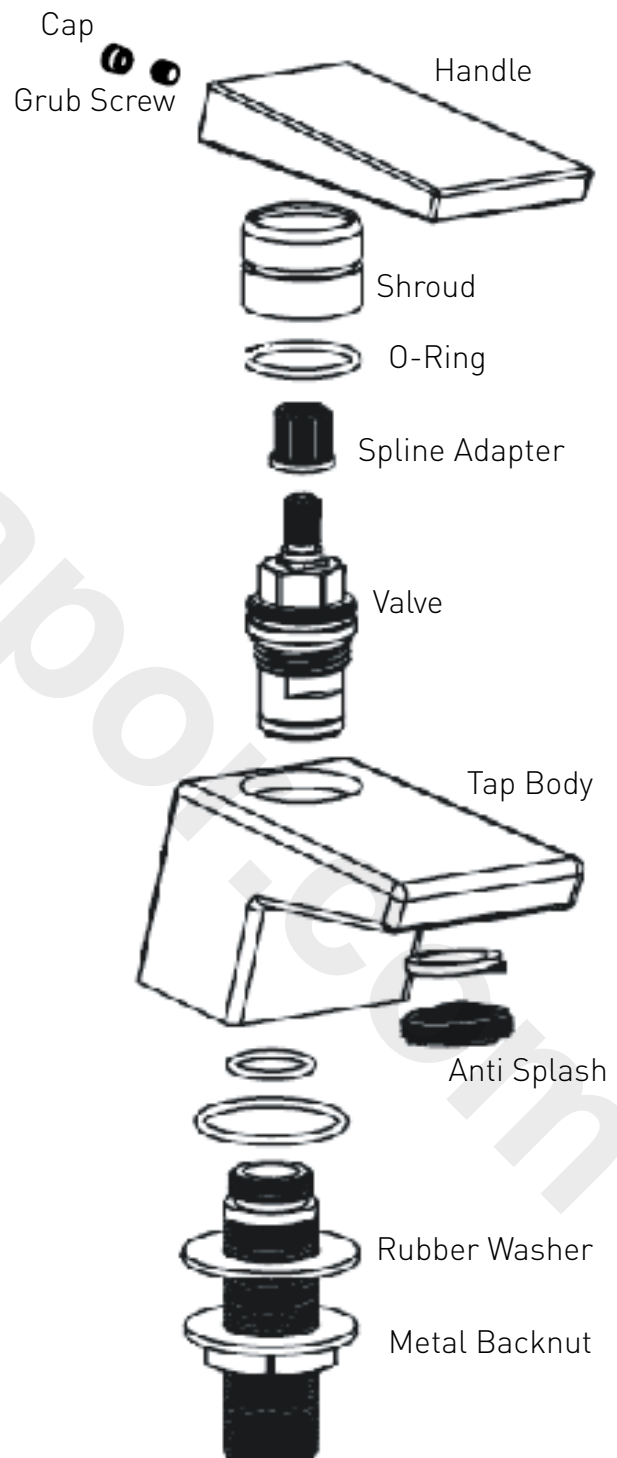

Maintenance cont.

Cleaning the Cartridge – Single Lever Basin Mixer

We advise that your fitting is regularly serviced in hard water areas to maintain optimum performance (see map of Hard Water Regions in the UK on page 15).

If your fitting begins to leak the following should be carried out;

Isolate both hot and cold water supplies to the tap by either:

- Turning the water supply off at the mains stopcock or
- Turning off the isolation valves to the tap.

1. Remove the grub screw at the rear of the handle.
2. Pull the handle upwards from the shroud.
3. Unscrew the shroud, remove the cartridge retaining nut and pull out the cartridge.
4. Carefully clean the cartridge seals and seating.
5. If necessary replace the cartridge.

Please visit www.bristan.com/sparesfinder in order to find spare parts for this product.

6. Replace the cartridge into the tap body and tighten retaining nut fully.
7. Replace all remaining components and turn on water supply.
8. Check for leaks and contact our helpline if problem persists.

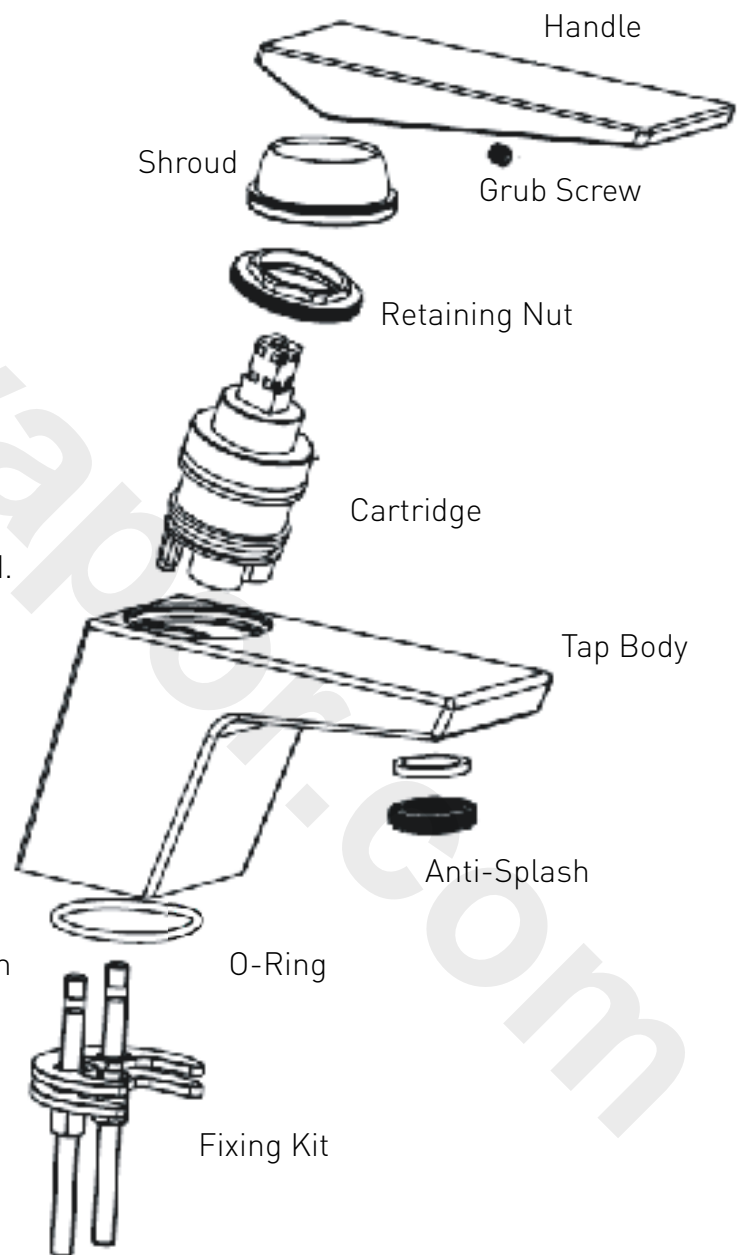

Map of Hard Water Regions in the UK



Soft to moderately soft
0 - 100mg/l as calcium carbonate equivalent

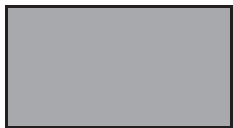

Slightly hard to moderately hard
100 - 200mg/l as calcium carbonate equivalent



Hard to very hard
Above 200mg/l as calcium carbonate equivalent

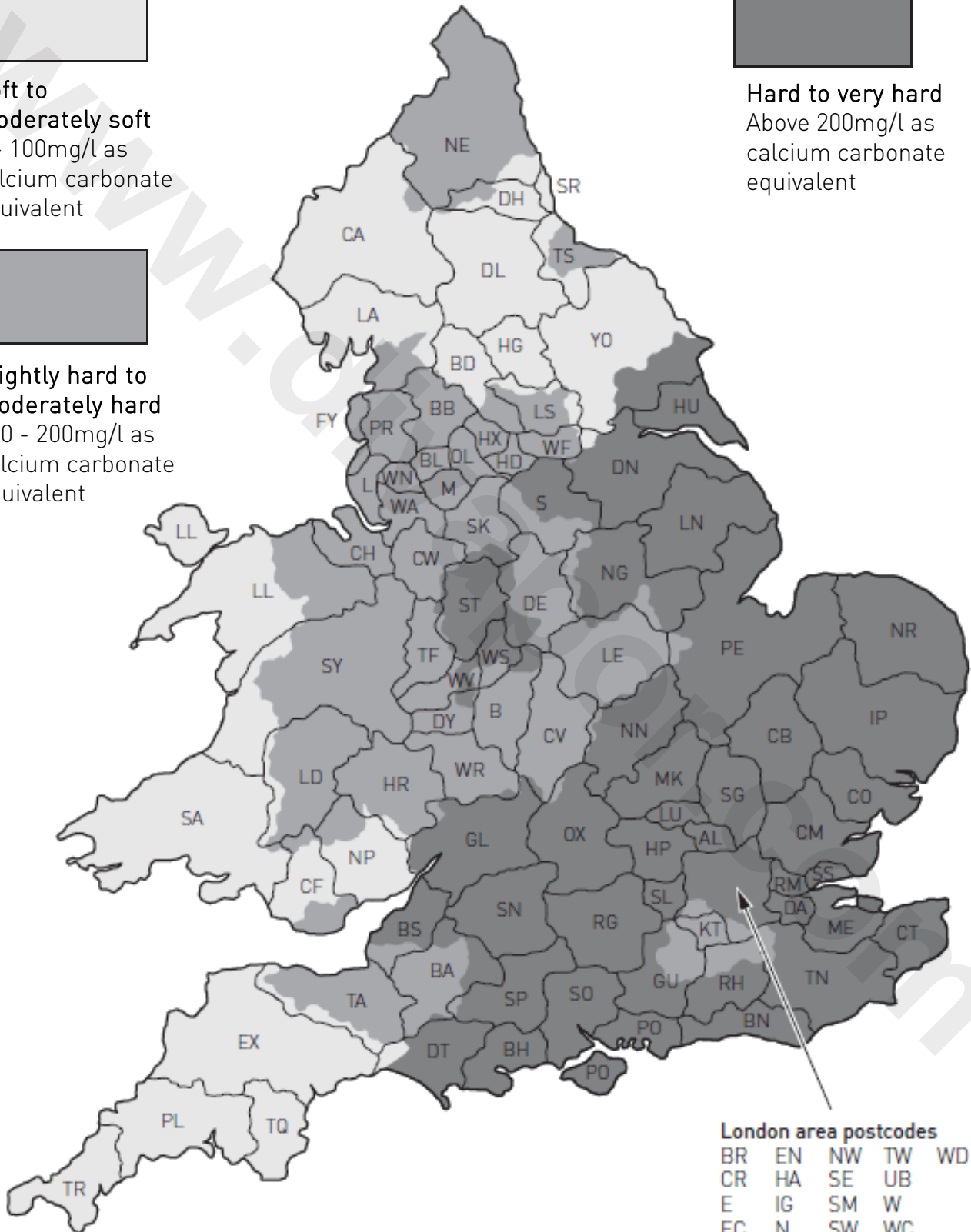

Troubleshooting

Symptom	Cause	Remedy
No flow or poor flow rate.	Partially closed stop or service valve in water supply pipework to the tap.	Open stop or service valve.
	Head of water is below the minimum distance required.	Refer to the Specification section for minimum pressures required.
	Possible airlock / blockage in supply pipework	Remove water supplies from the fitting and flush the system to remove any airlocks / debris.
	Cartridge / Valve not opening fully.	Service fitting. Refer to maintenance section on page 12-14.
Water dripping for a few seconds after the tap has been turned off.	This is caused by 'capillary action' and residual water in the spout being siphoned out. This should only last for a couple of seconds.	
Constant dripping / leaking when the tap is not in use.	Cartridge / Valve not fully shutting off.	Service fitting and replace cartridge / valve. Refer to maintenance section on page 12-14.
Fitting does not turn on.	Water supplies not turned on.	Check that the water supplies to the fitting are turned on.
	Closed stop or service valve.	Open stop or service valve.
Water does not come out of the showerhead when using the bath shower mixer.	Diverter mechanism not fully open.	Open the diverter mechanism fully by pulling the diverter knob up.
	Insufficient water pressure / header height.	Refer to the specification section for minimum pressures required.

Bristan Guarantee

Bristan offers solid guarantees to provide you with complete peace of mind.

Taps and Mixers

5 year parts and 1 year labour*. Gold, painted and special finishes 3 years parts only.

All subject to proof of purchase.

Mixer Shower Valves

5 year parts. 5 year labour* (subject to registration), or 1 year with proof of purchase.

Gold, painted and special finishes 3 years parts only.

Pumps and Power Showers

2 year parts. 1 year labour* (subject to registration).

Electric Showers/Instantaneous Water Heaters

2 year parts. 1 year labour* (subject to registration).

Accessories

5 year parts only. Includes bathrooms accessories, shower accessories (e.g. hoses, handsets and poles), wastes, WC levers and light pulls. Gold, painted and special finishes 3 years parts only.

Sanitaryware

5 year parts only. Subject to proof of purchase.

*Labour provided by an approved Bristan engineer. Guarantee only applies to products with a manufacturing fault. A deferred payment will be necessary in order to secure any visits by our engineers which will be charged if the problem is found **not** to be a manufacturing fault. If the fault is found to be down to a manufacturing error, the payment will be released and not charged.

This guarantee applies to products purchased within the United Kingdom or Republic of Ireland, but does not apply to products used commercially.

The guarantee is only available to original purchasers who have proof of purchase.

The installation must allow ready access to all products for the purpose of inspection, maintenance or replacement.

Any part found to be defective during the above guarantee period will be replaced without charge, providing that the product has been installed in accordance with the instructions, used as intended, and regularly serviced.

Servicing should be carried out at regular intervals of no more than 12 months and more frequently in hard water areas (heavy lime scale) areas.

In the unlikely event that any problems are encountered with the product's performance on installation, you must obtain guidance/authorisation from our Customer Service Department, and be able to supply proof and date of purchase, before any remedial action is taken.

The guarantee excludes general wear and tear and damage caused by accident, misuse or neglect, and does not cover the following:

- Components that are subject to general wear and tear such as filters, seals, 'O' rings and washers etc.
- Damage caused by faulty installation
- Damage caused by lime scale or any waterborne debris
- Damage caused by inappropriate cleaning products (see user instructions)
- Damage caused by the use of non-Bristan parts
- The product being used for a purpose other than intended by the manufacturer.

In the interests of continuous product improvement Bristan reserves the right to alter specification as necessary.



Guarantee

Notes

Please use this space to add any notes which you or your installer may have regarding the plumbing system / installation of this product.

www.divapor.com

Notes

Please use this space to add any notes which you or your installer may have regarding the plumbing system / installation of this product.

www.divapor.com

BRISTAN

This booklet covers product codes
SAI ½ C, SAI ¾ C, SAI BAS C, SAI BF C, SAI BSM C

Helpline

0844 701 6273

Bristan Group Limited

Birch Coppice Business Park, Dordon, Tamworth, Staffordshire B78 1SG

A Masco Company

Website: www.bristan.com

Telephone: 0844 7016 274 Facsimile: 0844 701 6275

Email: enquire@bristan.com